

**SME**

**MODEL 30/2**  
**PRECISION TURNTABLE**

*Instructions*

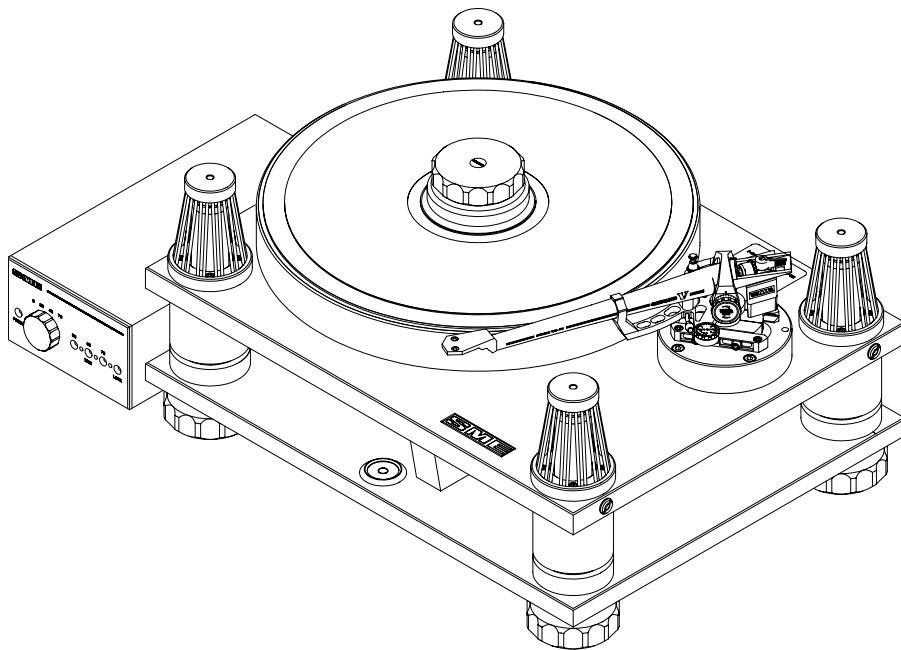

**SME****MODEL 30/2**

PRECISION TURNTABLE

## Instructions

This is no ordinary turntable. These instructions have been compiled covering unpacking, adjustment and installation procedures. Please read carefully as you proceed.

## **1. INTRODUCTION**

SME have manufactured pick-up arms for more than thirty years and the design and manufacturing experience gained has now been applied to the Model 30/2 precision turntable. It complements the Series V precision pick-up arm, *'the best pick up arm in the world'* and with this and comparable equipment can provide a listening experience that allows vinyl sound to be re-assessed. Detail, resolution, dynamic range and neutrality are of a new order, with an impressive lowering of the noise floor. As one listener remarked, 'No feeling of anything going round, just the master tape passing smoothly through'. For the fortunate owner of a record collection the Model 30/2 can be the key to a rich storehouse of listening pleasure.

## 2. CONTENTS

Page	
3	Introduction
5	Dimensions and specification
6	Packing list
7	Parts identification
8	Unpacking
9/10	Setting up
11/12	Operation
12	Maintenance
13	Transit precautions
14	Guarantee
15	Appendix

### 3. DIMENSIONS

Width	450mm (17.72")
Depth	350mm (13.78")
Height	220mm ( 8.66")
Platter Diameter	330mm (13.00")
Spindle to Arm	215.35mm (8.48")
Net Weight	42.0Kg (92 lbs)
Shipping weight	56.0Kg (123 lbs)

### 4. SPECIFICATION

Voltage Selector	AC 115 & 230v +/- 10%, 50/60Hz
Motor	Three phase, Eight-pole, Electronically commutated.
Power consumption	9W
Internal Fuse Rating	250mA TD 100-120 V AC 500mA TD 220-240V AC

#### **WARNING!**

This apparatus must be earthed.

### 5. SPEED RANGES

33 1/3, 45, 78 rpm, each with fine adjustment and extra wide 78 range for non-standard records.

## 6. PACKING LIST

Qty		Part No.
1	Model 30/2 base and sub-chassis assembly	1000
2	Suspension Bands (spares)	1020
1	Platter	1041
1	Syringe of Spindle Oil	1058/30
1	Trimming Tool for Speed Adjustment	1073
1	4mm A/F Hexagon Wrench	1083
1	Height Setting Gauge	1084
1	Stroboscopic Disc	1087
1	Operating Instructions	1088
1	Soft Cover	1094
1	Control Unit	1095PA
1	Power Cord	1098-9
1	Drive Belt	1100
1	Syringe of Lubricating Oil	1287
1	Oil Filler Adaptor	1129
1	Record Spindle Washer	1148
1	Record Clamp	1239A
1	Box Spanner	1946
4	M3 x 12 Socket Cap Screws	5893/12
1	2,5mm A/F Hexagon Wrench	5896
1	1,8M Audio Lead	5900A/30
1	3mm A/F Ball-ended Hexagon Wrench	5905
1	2,0mm A/F Hexagon Wrench	5924

## 7. PARTS IDENTIFICATION

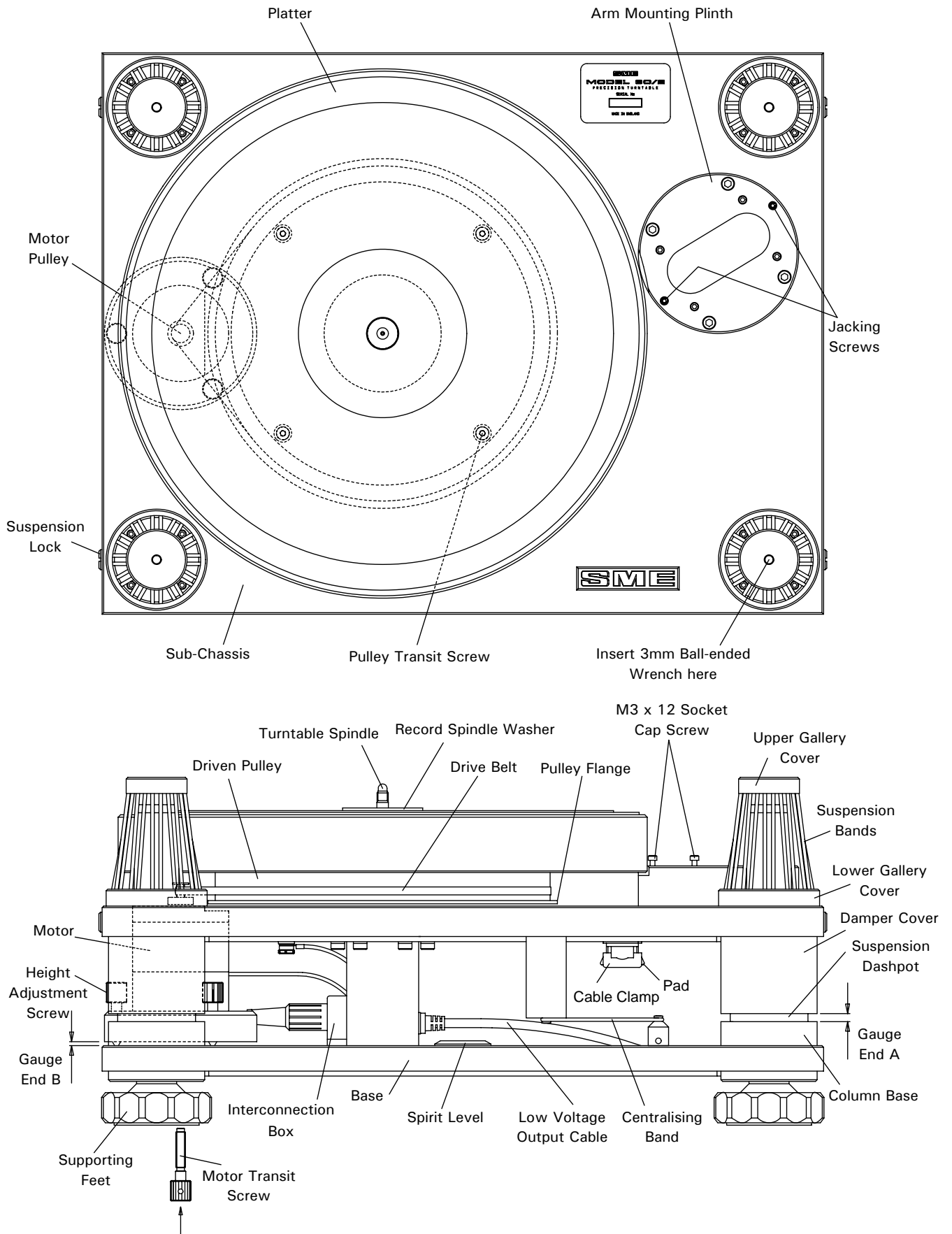

## 8. UNPACKING

1. Unpack and check all items against the packing list on Page 6. Any missing parts should be reported to your dealer at once.
2. The levelling feet allow for two methods of interface with the mounting surface.
  - a. As received on rubber insert pads set into the underside of the feet.
  - b. Stainless steel balls also set into the underside of the feet.

**WARNING:**

Method (b) is not suitable for delicate surfaces as indentation may be caused.

3. If hard mounting the turntable on the stainless steel balls is preferred, proceed as follows:
  - a. Position the base so that one end overhangs the table by about 10cms, unscrew and remove both of the exposed feet.
  - b. Remove the rubber pad from the foot by pushing out through the small hole on the upper side of the foot using the longer leg of the 2mm A/F hexagon wrench.
  - c. Replace the turntable feet and repeat the procedure for the two feet at the opposite end of the unit.
4. Having removed the lid of the packing case take out the tray containing the tools and accessories. Due to the weight of the Model 30/2 it is best lifted out of the case by two people, one at each end holding it under the sub-chassis. The turntable should be sited on a substantial table or steel equipment stand which must be capable of firmly supporting at least 45 kilos (100 lbs).
5. Position the base so that its left-hand end overhangs the table by about 10 cms (4"). This allows access to the transit screw which secures the motor and is beneath it. Remove this screw then restore the base to its normal position.
6. The turntable is packed with only a little oil in the bearing housing and this should now

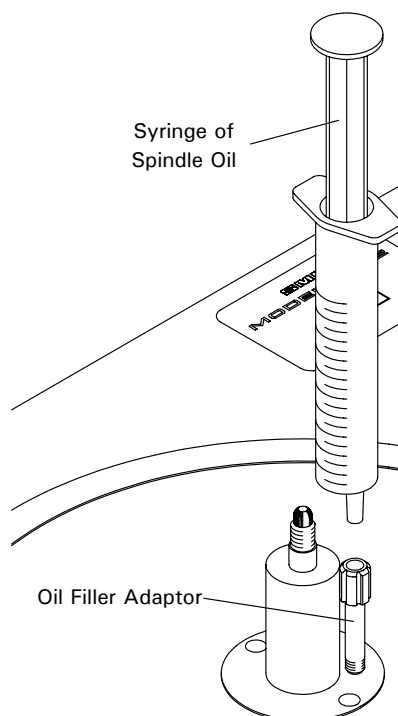

be filled. A metered charge is provided in Syringe Part No: 1058/30.

7. Remove the syringe from its packing and insert the tip into the Oil Filler Adaptor, which will be found already fitted to near the spindle. (as illustration left).
8. Slowly inject the complete quantity into the bearing maintaining downward pressure throughout the operation to prevent leakage.
9. Remove the syringe and dispose of it responsibly!
10. Unscrew and remove the Oil Filler Adaptor using the Box Spanner Part No: 1946. Retain the adaptor for possible future use.
11. For transit the suspension is secured by four locks, two at either end of the sub-chassis close to the columns.

Locking or unlocking requires five complete turns of the 3mm A/F ball-ended wrench which should be inserted into each lock in turn. When released the sub-chassis will rise under the pull of the suspension bands so have an assistant hold it firmly down until all the locks have been operated as damage could occur if one end lifts before the other.

## 9. SETTING UP

1. The motor is mounted on three height adjustment screws, the points of which nest in compliant cups in the base. For transit purposes these screws have been backed off clear of the compliant cups and the motor secured to the base with the Motor Transit Screw. This must be removed using the long leg of the 2,5A/F hexagon wrench as a lever through the cross hole in the head of the screw. The ends of the height setting gauge (1084) are marked A and B. Re-engage the points of the height adjustment screws with the compliant cups and adjust so that end B of the gauge is just admitted near each screw in turn between the underside of the motor and the surface of the base.
2. For transit the main bearing is off-loaded by the four pulley transit screws. These are captive and should be turned anti-clockwise with the 3mm A/F hexagon wrench until they stop. Ensure the wrench is fully engaged to avoid damage to the transit screw socket.
3. Unpack the drive belt and place it over the driven pulley. Press it down as far as the flange, ensuring that it is free from twists, then stretch it over the motor pulley. The pulleys will be out of alignment without the weight of the platter so rotation must not take place until it has been fitted.
4. Remove and unpack the platter from the bottom section of the case. Place it carefully and squarely over the turntable spindle and lower it gently down until it rests on the driven pulley, having first ensured that both mating surfaces are clean. Rotate the platter slowly by hand to position the belt on the pulleys.
5. The base should now be levelled by rotating the supporting feet until the bubble and reference ring of the spirit level are concentric. The feet will turn more readily if the corresponding corner of the base is lifted slightly at the same time.
6. The Model 30/2 is intended to receive an SME Series V precision pick-up arm and is supplied complete with a non-standard 1,8M (6 ft) audio lead, the plug contacts of which have been rotated through ninety degrees so the cable can leave the arm downwards.
7. If you are not already familiar with the Series V arm, carefully study its instruction book at this point. Fit the cartridge of your choice and feed the audio lead up through the cut-out in the arm mounting plinth. Do not over-tighten the four M5 x 30 socket cap screws holding the arm mounting plinth to the sub-chassis. The intended interface will be obtained if the screws are tightened holding the short leg of the hexagon wrench. Plug the lead into the arm, which should now be secured to the arm mounting plinth using the four M3 x 12mm socket cap screws provided. Two cable grips are fitted to the underside of the sub-chassis. Select whichever is the more convenient and remove the clamp by squeezing in the two release pads. Position the audio lead and re-fit the clamp, pushing it home just enough to secure the cable in a shallow loop so that it is held clear of the base.

8. The arm mounting plinth is fitted with jacking screws to facilitate removal from the sub-chassis. They should be turned clockwise, alternately in small increments until the plinth can be lifted off. A 2,0mm A/F hexagon wrench Part No. 5924 is provided for this purpose.
9. The upper gallery cover at the top of each of the four columns has a small central hole. To adjust the height of the sub-chassis insert the 3mm A/F ball-ended hexagon wrench engaging the socket within. Clockwise rotation will then raise the sub-chassis and the reverse will lower it.
10. The sub-chassis suspension should now be adjusted at each point so that end A of the height setting gauge (1084) will enter easily between the points indicated on page 7. If it is desired to increase sub-chassis isolation because of unusually close proximity to the speakers the recommended gap can be exceeded by up to 2mm. After adjustment hold the sub-chassis fully down, then release it. Check and readjust as needed, noting that new suspension bands take a little while to settle down. A single band arranged horizontally beneath the sub-chassis centralises it against the pull of the driving belt.
11. Rotate the platter slowly by hand to ensure that the drive belt takes up a central position on the crown of the motor pulley. If adjustment is required turn the motor height adjustment screw nearest to the edge of the base a little at a time, clockwise to raise the belt and anti-clockwise to lower it.
12. Unpack the control unit. ***DO NOT FIT THE POWER CORD AT THIS STAGE.*** The mains voltage setting is indicated on the external selector switch (SW1) mounted on the back panel. As a precaution it is set to 240v when leaving the factory.

The available settings are shown below. The last one is non-standard and intended for use with 115v mains that are subject to excessive voltage drop. To use this feature an internal selector switch (SW2) situated alongside the mains transformer is accessed after removing the unit cover, a small matter with which your dealer will gladly help.

Voltage Selector Switch Setting		
External Switch SW1	Internal Switch SW2	AC Mains Voltage +/-10%
240v	230v	230
120v	230v	115
120v	115v	100

***CHECK CAREFULLY YOUR MAINS VOLTAGE AND ADJUST THE DISPLAYED FIGURE AS NECESSARY BEFORE CONNECTING THE UNIT TO THE MAINS.***

13. The power cord supplied as standard has a moulded on mains plug. In the event that another type of plug must be fitted the original plug should be cut off and disposed of responsibly.

**WARNING!**

**THIS APPARATUS MUST BE EARTHED.**

14. Connect the low voltage output cable from the control unit to the turntable by inserting the DIN plug into the socket on the end of the interconnection box mounted at the rear of the base. *NOTE:* It is essential that this plug is fully engaged up to its emblem shoulder to ensure complete electrical engagement, it may be found helpful if the turntable platter is removed to increase the between chassis space available for this task. Ensure that this and any other leads are dressed clear of the suspension columns. Re-check that the voltage adjustment has been correctly made and plug the power cord into the control unit and the mains supply. An on-off switch is situated on the back of the control unit immediately above the mains socket.

## 10. OPERATION

1. The Model 30/2 precision turntable is partly run-in before leaving the factory but will further benefit from the first few weeks of use. Do not worry if initially is not totally silent. A slight 'swish' barely audible at very close range in a silent room will quickly disappear if the machine is left running continuously, one month is recommended. Speeds should be checked from time to time, preferably after about fifteen minutes running. Trimmers are mounted at the front of the control unit and operated with the speed adjustment tool (1073) in accordance with the following procedure:

Place the stroboscopic disc (1087) on the platter. Re-check the drive belt for centrality on the motor pulley and select the required speed with the rotary switch to start the platter. The disc should be viewed in fluorescent or neon light. The appropriate band will synchronise and appear stationary when the speed is correct, whilst clockwise and reverse movement will indicate fast and slow running respectively. This is best observed if the pick-up arm, with cartridge fitted and in the raised position, is placed directly over the band being viewed as a reference point. To adjust the speed the corresponding trimmer on the front panel is rotated with the trimming tool, clockwise to increase speed and the reverse to reduce it. The 'Lock' indicator lights continuously to show that speed is being accurately maintained.

2. Complete the arm and cartridge set-up procedures detailed in the Series V instruction book.
3. Place the record spindle washer on the spindle followed by the record and clamp. The latter should be screwed down clockwise enough to deflect the record flat into firm contact with the platter. With a fingertip tap the record in three places equally over its surface and with a little practice it will soon become evident whether or not the record is touching the platter. If not, some further tightening may be necessary but this is not always the answer however and sometimes releasing the clamp a little may do more to effect the desired improvement.
4. *The foregoing clamping instructions assume vinyl records, for shellac 78's the record washer should not be used for risk of breaking the record.*
5. The turntable is now ready for use. At this point packing and other items that are no longer required should be stored in the case so as to be available if needed in the future.

6. The Model 30/2 is not equipped with a lid as it would increase the likelihood of acoustic feedback but a soft cover is provided to protect the turntable from dust when not in use. The back should be fitted first and the cover then brought forward so that the front can be guided safely past the cartridge and stylus. When removing the cover start at the back and lift it upwards then forwards away from the front of the tone arm.

## 11. MAINTENANCE

1. There are no critical adjustments or need for 'tweak' and only very little maintenance. Clean the drive belt occasionally by drawing it through a piece of soft tissue or linen moistened with lighter fuel. The same material may be used to clean the periphery of the motor and driven pulleys. The main bearing is lubricated for life.
2. Having sintered bronze bearings the motor requires minimal lubrication. One drop of oil only in one year is sufficient and should not be exceeded. Remove the platter and drive belt. Apply one drop of 1287 oil from the syringe at the point indicated on top of the motor. Choose a time when the turntable will not be used for some hours so that the oil can find its way down to the lower bearing. After this time check that there is no oil on the motor pulley and replace the drive belt and platter. For cleaning the platter should be removed from the turntable whilst its surface is sponged with a soft cloth using warm water and washing-up liquid, followed by warm water only then a dry towel.
3. The suspension dashpots automatically seal when the sub-chassis is locked down and do not require maintenance.
4. Replace the drive belt after 1000 hours use. A replacement (Part No. 1100) is available from SME Limited.
5. The life of the suspension bands will depend on climatic conditions. If eventually they should stretch beyond further adjustment, replacements (Part No. 1020) are available from SME Limited.
6. Changing the bands is simple and may even be done while a record is playing ! Two spare bands are provided in case of accidental damage. Unscrew and remove the upper gallery cover from the top of the column and lift off the lower gallery cover. Remove the old band and replace the new one over the anchorage studs. Replace the covers and re-check the suspension height with the gauge.
7. There are no user-serviceable parts inside the control unit. A 500 milli-amp fuse is accessible beneath the mains input socket. Its replacement should only be undertaken by qualified service personnel.

## 12. TRANSIT PRECAUTIONS

The Model 30/2 can be safely transported

*SUBJECT ABSOLUTELY TO THE FOLLOWING PRECAUTIONS:*

Short journeys by car: remove the platter, disengage the drive belt from the motor pulley, back off the motor height adjustment and replace the motor transit screw. Lock down the

suspension. Screw down the four driven pulley transit screws lightly and evenly, just enough to prevent the pulley rotating. The turntable itself is best placed on the floor of the car in front of the passenger seat. The platter and other items can be stowed elsewhere provided they are carefully protected. For all other transportation purposes the original packing case and materials must be used.

### **13. GUARANTEE**

Your SME Model 30/2 precision turntable is guaranteed against faulty material and workmanship. The nominal period of the guarantee is twelve months but is liberally interpreted at our discretion subject to the following conditions being observed:

1. Any matter arising must in the first instance be raised with SME Limited at the address appearing below.
2. In no circumstances return the turntable or any part thereof to SME Limited unless we have requested you to do so. Responsibility will not be accepted for any items or costs arising if this point is disregarded.
3. Items returned to our Service Department must be:
  - a. Sent strictly in accordance with the packing and routing directions which we will provide.
  - b. Insurance should be effected by the owner. SME Limited are unable to accept liability for any items until they reach the factory safely.
4. Defective parts will be replaced free of charge. The cost of labour may be charged at the discretion of SME Limited. Return transport and insurance costs will be charged.
5. The guarantee expressly excludes:
  - a. Damage by any cause whatever.
  - b. Contingent and third party liability.
  - c. Personal injury.
6. No alteration or variation of the guarantee will be recognised by SME Limited.
7. The guarantee is not transferable.

SME Limited · Steyning · Sussex · BN44 3GY · England  
Tel: +44 (0)1903 814321 · Fax: +44 (0)1903 814269  
e-mail: [service@sme.ltd.uk](mailto:service@sme.ltd.uk)

## **14. APPENDIX**

We hope these instructions have made the installation of your Model 30/2 precision turntable straightforward. Care for it as befits its fine construction. Do not invert it. Do not apply oil or other lubricant except as directed. Do not attempt to take it to pieces or interfere with any of the screws except as directed in the instructions. To do so will invalidate the warranty and may occasion costly repairs. Keep your turntable clean by dusting it regularly with due regard for the safety of the cartridge and stylus. Always use the soft dust cover when not in use. Finger marks may be removed from the black enamel/chrome finish with a linen handkerchief moistened with lighter fuel. Do not use any other kind of spirit or solvent cleaner.

In the unlikely event of a problem concerning operation or service, always contact us in the first instance at the address on page 14, stating the exact nature of the problem, the name and address of the dealer who supplied the unit and its serial number which will be found on the rear of the sub-chassis by the arm mounting plinth.